

Part number

# CAPS 10.21



## Brief description:

surface mounting housings with 2 levers, size "57.27", Pg21, EMC version, IP66

### Product description

<b>Version</b>	EMC version
<b>Series</b>	surface mounting housings with 2 levers
<b>Product type</b>	with 2 levers
<b>Style</b>	high construction
<b>Family</b>	CLASS enclosures
<b>Size</b>	size "57.27"

### Technical data

<b>Material</b>	metal
<b>IP degree of protection</b>	IP66 (and IP69K DIN 40050 - 9)
<b>Cable entry</b>	Pg21

### Further technical details

<b>Weight</b>	373,00 g
---------------	----------

### Approvals / Standards

<b>Quality mark</b>	 (type:4/4X/12),  , EAC
<b>Conformity</b>	CQC, CE

### General ordering information

<b>EAN13 code</b>	8015747147453
<b>Tariff number</b>	85369095

### Packaging Information

<b>Packaging length</b>	475,00 mm
<b>Packaging height</b>	200,00 mm
<b>Packaging width</b>	150,00 mm
<b>Packaging weight</b>	3,73 kg
<b>Packaging volume</b>	14,25 dm <sup>3</sup>
<b>Packaging description</b>	Carton box
<b>Packaging quantity</b>	10 Pcs
<b>Packaging EAN code</b>	8015747248846
<b>Sub-packaging weight</b>	1,87 kg
<b>Sub-packaging description</b>	Plastic packaging
<b>Sub-packaging quantity</b>	5 Pcs
<b>Sub-packaging EAN barcode</b>	8015747248853

Part number

# CAPS 10.21



Catalogue drawings

## CHIS

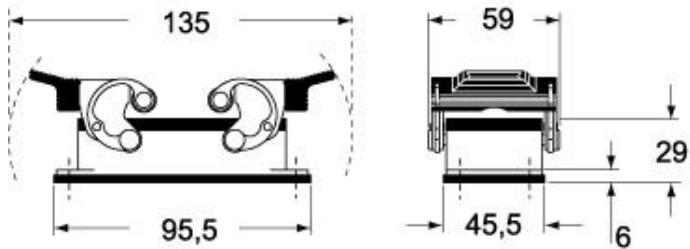

## CAPS - MAPS

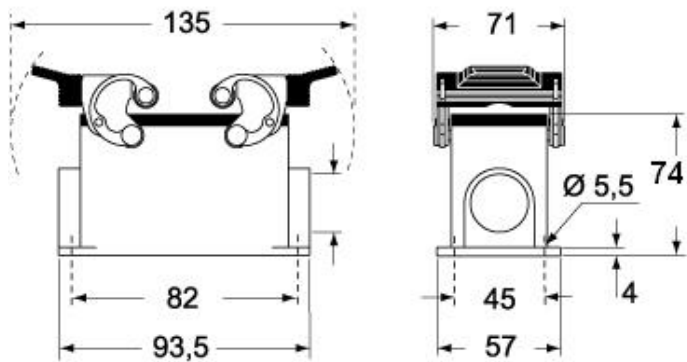

## CHCS

